



MODEL 6068

OPERATOR'S MANUAL

ASSOCIATED

- Model 6068 Battery Charger is designed to charge 12 volt batteries in parallel. The multiple charge rates allow batteries to be slow charged or fast charged at a rate not to exceed 110 amps output of the charger.
- This unit is not intended as a car starting unit. The output leads are terminated in ring terminals designed to be permanently attached to a parallel charging rack.

IMPORTANT SAFETY INSTRUCTIONS

1. **SAVE THESE INSTRUCTIONS.** This manual contains important safety and operating instructions for battery charger Model 6068. You may need to refer to these instructions at a later date.
CAUTION. To reduce risk of injury, charge only wet cell, lead-acid, automotive type rechargeable batteries. Other types of batteries may burst causing personal injury and property damage.
2. Do not expose the charger to rain or snow if specifically warned on the unit not to do so.
3. Use of an attachment not recommended or sold by the battery charger manufacturer may result in a risk of fire, electric shock, or injury to persons.
4. Do not operate the charger if it has received a sharp blow, been dropped, or otherwise damaged in any way; take it to a qualified serviceman.
5. Do not disassemble the charger unless you are qualified to work on electrical products. If not, take it to a qualified service technician when service or repair is required. Incorrect reassembly may result in risk of electric shock or fire.
6. To reduce the risk of electric shock, disconnect power to the charger at the disconnect box (user supplied) or at fuse panel before attempting any maintenance or cleaning. Turning off the controls will not reduce this risk.
7. **WARNING - RISK OF EXPLOSIVE GASES**
 - a. WORKING IN VICINITY OF A LEAD-ACID BATTERY IS DANGEROUS. BATTERIES GENERATE EXPLOSIVE GASES DURING NORMAL BATTERY OPERATION. FOR THIS REASON IT IS OF UTMOST IMPORTANCE THAT EACH TIME BEFORE USING YOUR CHARGER, YOU READ THIS MANUAL AND FOLLOW THE INSTRUCTIONS EXACTLY.
 - b. To reduce the risk of battery explosion, follow these instructions and those published by the battery manufacturer and manufacturer of any equipment you intend to use in vicinity of the battery. Review cautionary markings on these products.
8. **PERSONAL PRECAUTIONS**
 - a. Someone should be within range of your voice or close enough to come to your aid when you work near a lead-acid battery.
 - b. Have plenty of fresh water and soap nearby in case battery acid contacts skin, clothing, or eyes.
 - c. Wear complete eye protection, and clothing protection. Avoid touching eyes while working near battery.
 - d. If battery acid contacts skin or clothing, wash immediately with soap and water. If acid enter eyes, immediately flood eyes with running cold water for at least 10 minutes and get medical attention immediately.
 - e. NEVER smoke or allow a spark or flame in vicinity of the battery or engine.
 - f. Be extra cautious to reduce risk of dropping a metal tool onto the battery. It might spark or short circuit the battery or other electrical parts that may cause an explosion.
 - g. Remove personal metal items such as rings, bracelets, necklaces, and watches when working with a lead-acid battery. A lead-acid battery can produce a short circuit current high enough to weld a ring or the like to metal, causing a severe burn.
 - h. Use this charger for charging a LEAD-ACID battery only. It is not intended to supply power to a low-voltage electrical system other than in an automotive application. Do not use this battery charger for charging dry-cell batteries that are commonly used with home appliances. These batteries may burst and cause injury to persons and damage to property.
 - i. NEVER charge a frozen battery.
9. **PREPARING TO CHARGE**
 - a. When removing the battery from the vehicle to charge, always remove the grounded terminal from the battery first. Make sure all accessories in the vehicle are off, so as not to cause an arc.
 - b. Be sure the area around the battery is well ventilated while the battery is being charged. Gas can be forcefully blown away by using a piece of cardboard or other non-metallic material as a fan.
 - c. Clean the battery terminals. Be careful to keep corrosion from coming in contact with eyes.
 - d. Add distilled water in each cell until battery acid reaches level specified by the battery manufacturer. This helps purge excessive gas from cells. Do not overfill. For a battery without cell caps, carefully follow the manufacturer's recharging instructions.
 - e. Study all battery manufacturer's specific precautions such as removing or not removing the cell caps while charging and the recommended rates of charge.
 - f. Determine voltage of battery by referring to car owner's manual and make sure that output voltage selector switch is set at correct voltage. If charger has adjustable charge rate, charge battery initially at lowest rate.
10. **CHARGER LOCATION**
 - a. Place the charger as far away from the battery as the DC cables permit.
 - b. Never place the charger directly above the battery being charged; gases from the battery will corrode and damage the charger.
 - c. Never allow battery acid to drop on the charger when reading the specific gravity or filling the battery,
 - d. Do not operate the charger in a closed-in area, or restrict ventilation in any way.
 - e. Do not set a battery on top of the charger.

11. DC CONNECTION PRECAUTIONS

- a. Connect and disconnect the DC output clamps only after setting the charger switches to the **OFF** position from the electric outlet. Never allow the clamps to touch each other even with charger turned off.
- b. Attach the DC clamps to the battery post and twist or rock back and forth several times to make a good connection. This tends to keep the clamps from slipping off the terminals and helps to reduce the risk of sparking.
- c. NEVER touch the charger leads or rock the clamps when the charger is "ON". This can break the connection at the battery and cause an explosion.
- d. NEVER break "live" circuits at the battery terminals because it may spark. Always be sure the charger is "OFF" before removing the charger leads from the battery.

12. FOLLOW THESE STEPS WHEN THE BATTERY IS OUTSIDE THE VEHICLE. A SPARK NEAR THE BATTERY MAY CAUSE BATTERY EXPLOSION. TO REDUCE THE RISK OF A SPARK NEAR THE BATTERY:

- a. Read section "STOP/GO LITE INSTRUCTIONS" before proceeding.
- b. Check the polarity of the battery post. The POSITIVE (POS, P, +) usually has a larger diameter than the NEGATIVE (NEG, N, -) post.
- c. Attach at least a 24 inch long 6-gauge (AWG) insulated battery cable to the NEGATIVE (NEG, N, -) battery post.
- d. Connect the POSITIVE (RED) charger clamp to the POSITIVE (POS, P, +) post of the battery.
- e. Touch the contact button of the STOP/GO LITE to the free end of the battery cable. If the red light comes on, reverse the connections to the battery and retest. When the green light come on, position yourself and the free end of the cable as far away from the battery as possible, then connect the NEGATIVE (BLACK) charger clamp to the free end of cable.
- f. Do not face the battery when making the final connection.
- g. When disconnecting the charger, always do so in reverse sequence of connecting procedure, and break the first connection while standing as far away from the battery as practical.
- h. A marine (boat) battery must be removed and charged on shore. To charge it on board requires equipment specially designed for marine use.

13. GROUNDING INSTRUCTIONS

This battery charger should be connected to a grounded, metal, permanent wiring system, or, an equipment-grounding conductor should be run with circuit conductors and connected to equipment-grounding terminal or lead on battery charger. Connections to battery charger should comply with all local codes and ordinances.

14. AC POWER CONNECTION

- a. Wire to 190-262 volt single phase 50/60 cycle supply. Wiring and size must meet local and national electrical codes and carry 15 amperes.
- b. Measure the voltage across the two hot leads that will be supplying voltage to the charger.
- c. Remove the left side panel of the charger.
- d. Bring the AC wiring in through the strain relief connector in the lower right corner of the back panel.
- e. Connect one hot leg to terminal strip marked "Hot Leg". Connect the other hot leg to voltage tap nearest to the voltage measured in Step b. If measured voltage is between two voltage taps, connect to the tap of higher voltage. Connect the neutral wire to the ground screw on the base of the charger.
- f. Tighten the strain relief connector leaving only the minimum amount of extra wire in the charger.
- g. When connecting the charger to a charging rack, always be sure the connections are made with the correct polarity. The positive lead on the charger is marked with red tape.

15. MOUNTING INSTRUCTIONS

- a. Mount angle brackets securely to the wall 8-1/2 inches apart.
- b. Place charger and shelf assembly on brackets.
- c. Center shelf on brackets and screw brackets to shelf with screws provided.

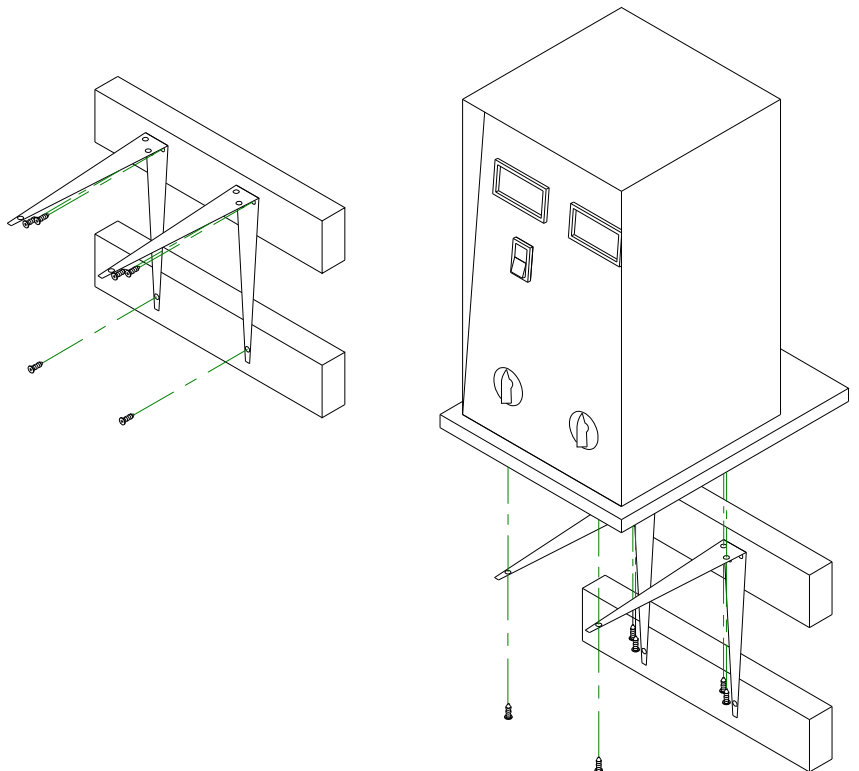

16. OPERATING INSTRUCTIONS

CONTROLS:

- a. AMMETER The ammeter shows the total amount of charge the batteries are receiving. The amount each battery receives depends on several factors (see Parallel Charging). The charger's full output of 110 amps and that amount should never be exceeded.
- b. VOLTMETER The voltmeter shows the voltage at which the batteries are charging. The amount of voltage applied to a battery will determine the amount of current the battery will receive. See the section on Charging Batteries for a complete description of the voltmeter and its use.
- c. SWITCHES The charger has two switches used to adjust the output voltage and current. Moving the "fine" switch from Lo to Hi does not increase the charging voltage as much as moving the "coarse" switch from a low position to a higher position. This design allows you to have 16 distinct charge rates.

CAUTION: This battery charger must be fully assembled before operating. Failure to do so may result in risk of injury.

TO CHARGE 12 VOLT BATTERIES:

- a. This charger is designed to charge all standard 12 volt automotive batteries.
- b. There are four types of batteries; standard, recombination, low maintenance, and maintenance free.
 - 1. "Standard" batteries have both negative and positive plates of lead-antimony alloy.
 - 2. "Recombination" batteries are sealed and have no free electrolyte. The gases produced in charging are "recombined" and recycled to the plates and separators. If charged at voltages higher than recommended, the gases will not be able to recombine quickly enough to prevent permanent water loss from the battery.
 - 3. "Low maintenance" batteries have one plate made from lead-antimony and one made from a lead-calcium alloy. This reduces gassing and water loss.
 - 4. "Maintenance free" batteries have both plates made from lead-calcium alloy.
- c. If two types of batteries are to be charged at one time, do not exceed the lower of the recommended end of charge voltages.
- d. As a group of batteries are charged, the output current of the charger will decrease and the output voltage will rise.
- e. For fast charging, keep the voltage adjusted to the top of the acceptable range, being careful not to exceed the current rating of the charger.
- f. For overnight charging, adjust the voltage at start of charge to be $\frac{3}{4}$ to $1\frac{1}{4}$ volts less than the maximum acceptable voltage. As the current drops, the voltage will climb. The number of batteries, temperature, and the state of charge of the batteries will all effect the charging characteristics. Experience will be the best teacher when it comes to your particular set of charging circumstances.
- g. If the batteries are to be "float" charged for more than 24 hours, the voltage should be turned down to 13.5 or less to prevent excessive gassing of the batteries.

PARALLEL CHARGING

- a. Connecting the batteries in parallel (see illustration) allows a person to charge a number of batteries at one time using only one 12 volt charger.
- b. The amount of charge being put into the batteries should not exceed the rating of the charger.
- c. The amount of charge that each battery receives will depend upon the state of charge, condition, and temperature of all the batteries being connected together and other factors.
- d. Connecting discharged batteries to a rack of fully charged batteries will not cause the charged batteries to become discharged.
- e. When a rack of batteries have various states of charge, the most discharged battery will receive the largest amount of charge first. Once it is charged up equal to another battery, then the two will charge together at an equal rate (see illustration).

DARK AREA REPRESENTS STATE OF CHARGE AT:

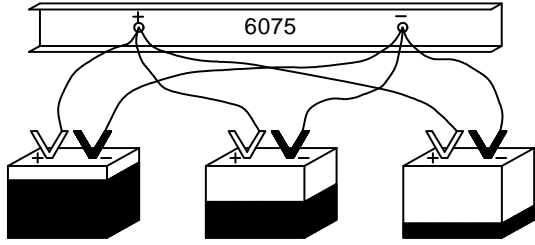

START OF CHARGE

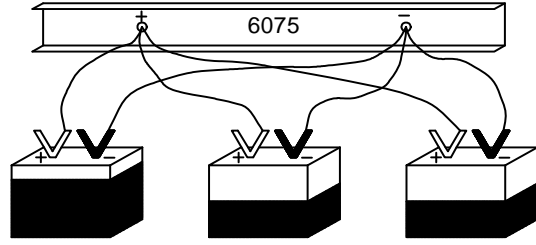

DURING CHARGE

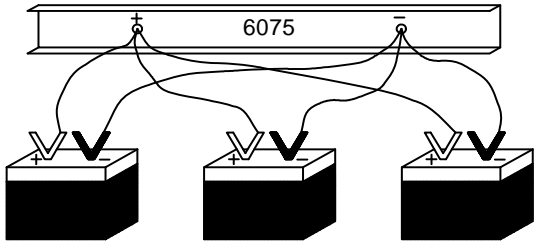

LATER DURING CHARGE

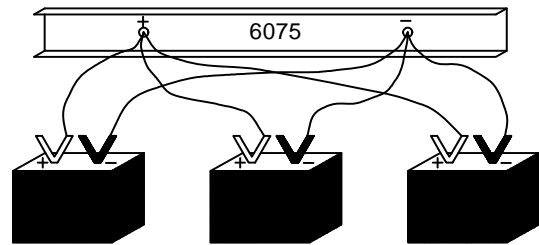

END OF CHARGE

TO CHARGE 6 VOLT BATTERIES:

- a. Six volt batteries must be charged in pairs (2 at a time).
- b. The 6 volt batteries must be connected in series (positive post of one battery to the negative post of the other battery) and then connected in parallel with other batteries.
- c. Never connect one 6 volt battery to the charger.
- d. Only 12 volt and pairs of 6 volt batteries may be charged with this unit. No other voltage battery may be charged with this charger.

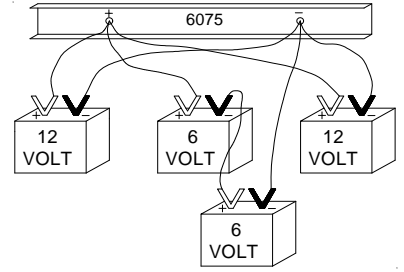

END OF CHARGE

- a. Discontinue charging when the specific gravity reading does not change in 3 consecutive readings, battery is freely gassing or when the electrolyte reaches 120 degrees Fahrenheit. If your battery is sealed and these determinations cannot be made, see manufacturer's instructions for charging.

WIRING DIAGRAM

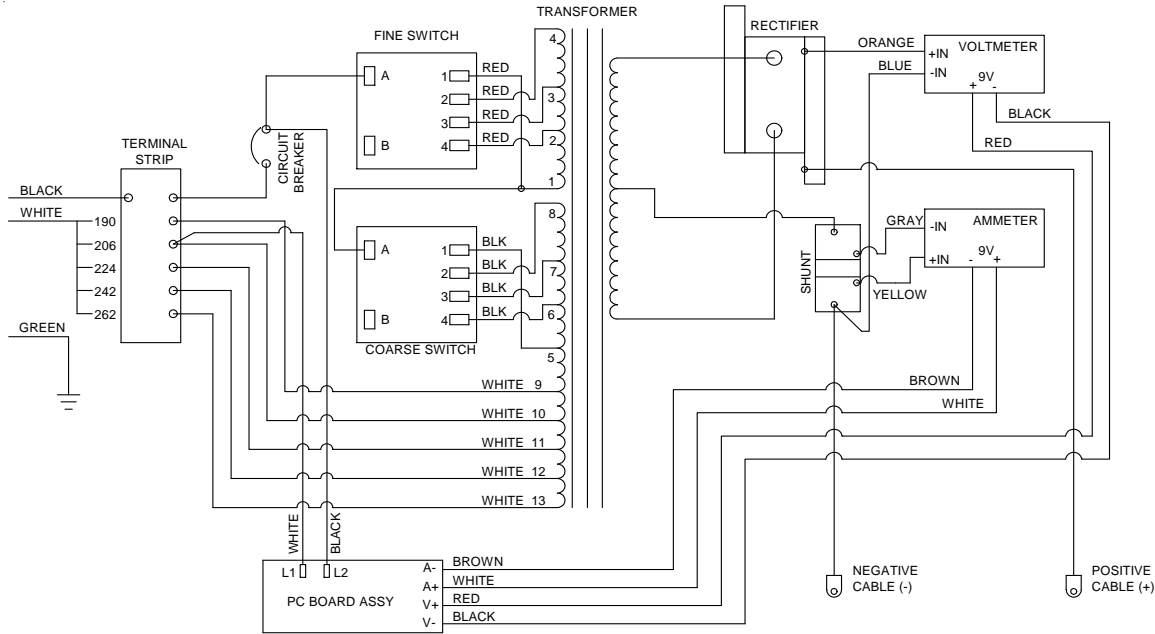

MODEL 6068 PARTS LIST

Transformer	610900	On/Off Breaker (1)	610272	Switch with knob (1).....	605675
Diode.....	610275	DC Cable set	610276	Clamps (1pair, includes jaws).....	6202
Ammeter	610891	Voltmeter	610890	Jaw Kit (repairs 1 clamp)	6204
P.C. Board	610901	Bezel w/hardware	610899		

Parts may be purchased from your local authorized service depot listed in the Service Procedure manual supplied with your product. If you elect to order parts from the factory you may do so by mail or phone. Minimum order from the factory is \$25.00. Orders received that are under the minimum will not be processed. Taxes and freight are extra and are not considered to be part of the dollar value of the order. We **do not** have a C.O.D. policy. Cashier check, money order, MasterCard or VISA are acceptable. If you use a MasterCard or VISA send only the number and expiration. **DO NOT SEND THE CARD.**

MAINTENANCE INSTRUCTIONS

Any Maintenance or repair of this unit that involves disassembly of the cabinet should be done only by a qualified service technician. Incorrect reassembly may result in a risk of electric shock when the unit is subsequently used.

ASSOCIATED EQUIPMENT CORPORATION
 5043 Farlin Avenue St. Louis, MO 63115
 Tel. (314) 385-5175 Fax. (314) 385-3254
 www.associatedequip.com